

SH PMG-W

SH PRC-W



For Soundhole diameter
SH PMG-W: 3.8 to 4.2in [96 to 106mm]

PanaMag Wireless Transmitter System for Acoustic Guitars

Shadow[®]
technology with performance.



Thank you very much for your interest in our products!

Before you power on the unit, please take the time to carefully read this manual to learn how the system works. You must read all safety instructions to ensure proper handling. If you still have additional questions, please feel free to ask us.

<http://www.shadow-electronics.com>

Safety Instructions

- △ Read and follow all instructions. Keep this instruction and heed all warnings!
- △ Refer all servicing to qualified service personnel. Servicing is required when the apparatus has been damaged in any way, such as power-supply cord or plug is damaged, liquid has been spilled or objects have fallen into the apparatus, the apparatus has been exposed to rain or moisture, does not operate normally, or has been dropped
- △ Never open or damage the battery. Follow the safety instructions about handling
- △ WARNING: To reduce the risks of fire do not expose this apparatus to rain or moisture.
- △ Do not use this system near a heart pace meter or other sensitive electronics. (E.g. Airplane, Transmitter, Hospital)
- △ Any unauthorized changes or modification will immediately void the warranty.
- △ This unit complies all technical requirements of FCC and CE.

Safety Instructions for Lithium Ion Battery







- △ Do not disassemble or modify the battery pack. The battery pack is equipped with built-in safety/protection features. Should these features be disabled, the battery pack can leak acid, over-heat, emit smoke, burst and/or ignite.
- △ Do not connect the positive (+) and negative (-) terminals with a metal object such as wire.
- △ Do not discard the battery into fire or heat it. Otherwise its gas release vent or safety features will be damaged and/or its electrolyte can ignite, possible leading to acid leakage, over-heating, smoke emission, bursting and/or ignition on it.
- △ Do not immerse the battery in water or seawater and do not allow it to get wet. Otherwise, the protective features in it can be damaged, it can be charged with extremely high current and voltage, abnormal chemical reactions may occur in it, possibly leading to acid leakage, smoke emission, bursting and/or ignition, inhibiting recharging, or can damage the built-in protective features, causing it to be charged with an extremely high current and voltage and, as a result, abnormal chemical reactions can occur in it, possible leading to acid leakage, over-heating, smoke emission, bursting and/or ignition.

FCC Declaration

- △ This device complies with Part 15 of the FCC Rules. Operation is subject to the following two conditions:
 - (1) this device may not cause harmful interference, and
 - (2) this device must accept any interference received, including interference that may cause undesired operation.
- △ Changes or modifications not expressly approved by the party responsible for compliance could void the user's authority to operate the equipment.
- △ The device for the band 5150-5250 MHz is only for indoor usage to reduce potential for harmful interference to co-channel mobile satellite systems.
- △ This equipment generates, uses, and can radiate radio frequency energy and, if not installed and used in accordance with the instruction manual, may cause harmful interference to radio communications. Operation of this equipment in a residential area is likely to cause harmful interference in which case the user will be required to correct the interference at his/her own expense.

CE Mark Warning

- △ This equipment complies with the requirements relating to electromagnetic compatibility, EN 55022 class A for ITE, the essential protection requirement of Council Directive 89/336/EEC on the approximation of the laws of the Member States relating to electromagnetic compatibility
- △ Company has an on-going policy of upgrading its products and it may be possible that information in this document is not up-to-date.
- △ Please check with your local distributors for the latest information. No part of this document can be copied or reproduced in any form without written consent from the company

 Contains FCC ID: QLPSAM88	 MIC ID: 204-320137		 Indoor use	 RoHS 2002/95/EC	 WEEE Reg. Nr.: DE 42527131
---	--	---	---	---	--

WEEE

- △ Information on Disposal for Users of Waste Electrical & Electronic Equipment:
- △ This symbol on the product means that used electrical and electronic products should not be mixed with general household waste. For proper treatment, recovery and recycling, please take this product to designated collection points where it will be accepted free of charge.
- △ Alternatively, in some countries you may be able to return your products to your local retailer upon purchase of an equivalent new product.
- △ Disposing of this product correctly will help save valuable resources and prevent any potential negative effects on human health and the environment, which could otherwise arise from inappropriate waste handling.
- △ Please contact your local authority for further details of your nearest designated collection point.
- △ Penalties may be applicable for incorrect disposal of this waste, in accordance with you national legislation.

Information on Disposal in other Countries outside the European Union

- △ WEEE: This symbol is only valid in the European Union. If you wish to discard this product please contact your local authorities or dealer and ask for the correct method of disposal.

Controls of the Transmitter

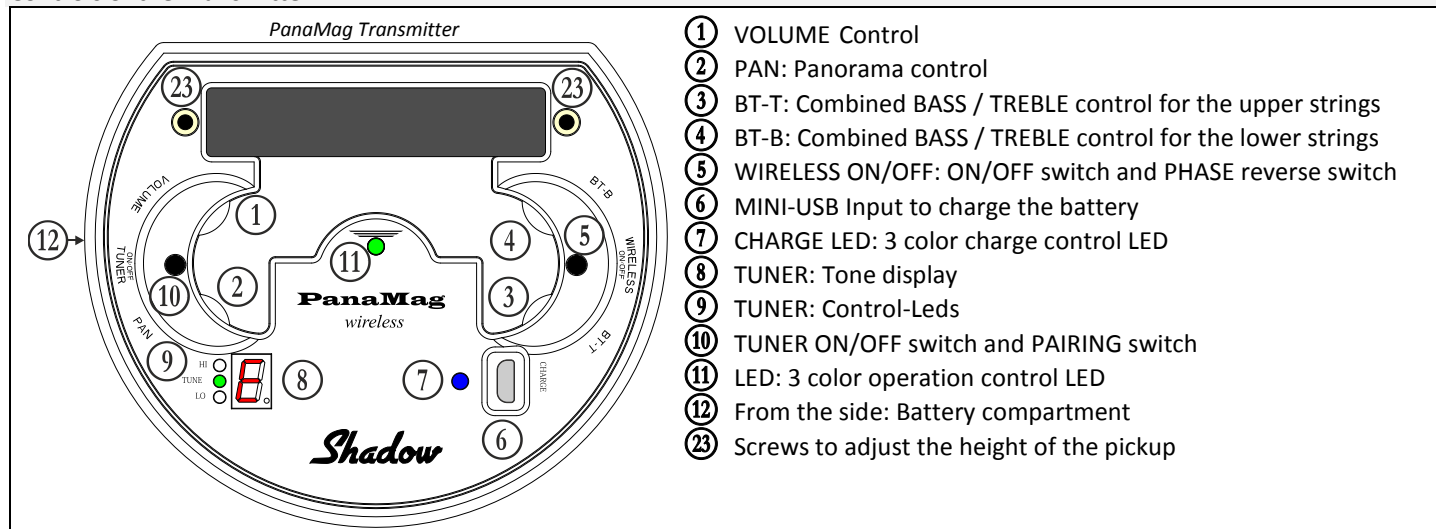

- ① VOLUME Control
- ② PAN: Panorama control
- ③ BT-T: Combined BASS / TREBLE control for the upper strings
- ④ BT-B: Combined BASS / TREBLE control for the lower strings
- ⑤ WIRELESS ON/OFF: ON/OFF switch and PHASE reverse switch
- ⑥ MINI-USB Input to charge the battery
- ⑦ CHARGE LED: 3 color charge control LED
- ⑧ TUNER: Tone display
- ⑨ TUNER: Control-Leds
- ⑩ TUNER ON/OFF switch and PAIRING switch
- ⑪ LED: 3 color operation control LED
- ⑫ From the side: Battery compartment
- ⑬ Screws to adjust the height of the pickup

Accessories

- Stereo PanaMag Preamp / Transmitter with installation material to fit different soundholes
- 3.7V LI-ION battery
- 5V USB Charger with two USB cables (*Type A to Micro B*)
- Stereo Panorama Receiver: PRC-W

Installing the PanaMag transmitter

- Use the adhesive foam strips to increase the diameter of the transmitter. For best results it should be neither too loose nor too tight. If it is too tight, you may damage the sound hole or of your guitar other part. It is too loose the transmitter may fall off during playing.
- Adjust the height of the pickup with both screws ⑬. The distance to the strings should be around 5mm. If it is too close distortion may occur. In this case increase the distance to the strings.

Inserting / changing the LI-ION battery

The transmitter uses a very common and easy to get rechargeable 3.7V Lithium Ion battery. Replace or change the battery if the capacity drops down or the battery cannot be recharged anymore.

- Remove the transmitter from the guitar sound hole.
- **Fig.4:** Bend the lid (B) to remove the battery. If the battery is too tight, you can assist the removal by carefully pushing a small screwdriver/pin through the rear hole (C).
- When re-inserting the battery always make sure battery contacts match the contacts inside the battery compartment (A).
- If you insert the battery in any other way the unit cannot operate.
- The lid (B) will lock the battery in place after inserting the battery.
- The battery has a capacity of ~1600mA/h up to 1800mA/h. The battery may last up to 6 hours.
- The full capacity of the battery may not be reached if the environment temperature is extremely low or high.
- Use normal room temperature to operate or charge.
- You can always recharge the battery, even if it is not empty. LI-ION batteries don't have the "Memory Effect" like N-Mh batteries!

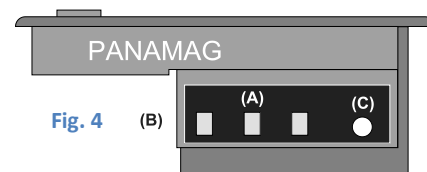

Fig. 4

When handling with LI-ION batteries read the safety instructions first!

Battery Low Warning

The voltage of the battery will be periodically checked. Below a certain level – which means the battery capacity is diminished – the red part of the LED ⑪ starts to flash slowly. After further dropping of the battery voltage, which means the capacity will be off shortly, the red part of the LED ⑪ starts to flash fast. Then you should recharge the battery soon.

- **CHARGING:** Before you can use the unit the first time charge the battery as follows:
 - Connect the USB cable between the charger and the USB socket ⑥ of the transmitter.
 - Or alternative: If the receiver is connected to the USB charger (*Yellow LED is on*) connect the 2nd USB cable between USB socket ④ of the receiver and the USB socket ⑥ of the transmitter.
 - Note: Connecting the Charger switches the transmitter off!
 - Charge time may be up to ~6 hours. This depends on the overall condition of the battery.
- The CHARGE LED ⑦ shows the state of charging:
 - White: **PRE CHARGE MODE** (Depends on the battery's capacity)
 - Purple: **FAST CHARGE MODE**
 - Cyan: **DONE**
 - Blue: **ERROR:** E.g. Battery missing, short or defect or thermal error

Note:

- ★ If the battery is full, the mode may alternate between "Fast Charge Mode" and "Done"
- ★ During charging the unit will be switched off automatically!

CONTROLS

△ **Note:** The tact switches have double function: You can either press it for a short time or hold it for a longer time (~1 sec.)

- **LED Info:** The LED (11) indicates several different modes.
- **SWITCH ON: NORMAL PLAY MODE**
 - Press the switch WIRELESS ON/OFF (5), to switch the unit on. This activates RF transmitting too
 - Blue shows the wireless connectivity: Blink: No connection. On: Connection established.
- **SWITCH ON: TUNER ONLY MODE**
 - Press the switch TUNER ON/OFF (10), to switch the unit on (**TUNER ONLY MODE**) without transmitter function
 - To switch it off again hold the switch TUNER ON/OFF (10) or WIRELESS ON/OFF (5) for a longer time (~1 sec.)
 - If the tuner is not in use (*no input signal*) for ~90 sec. the transmitter switches off automatically!
- **SWITCH OFF**
 - Press and hold (~1 sec.) the switch WIRELESS ON/OFF (5), to switch the unit off.
- **TUNER IN NORMAL PLAY MODE ON**
 - Press the switch TUNER ON/OFF (10), to start the tuner operation. This mutes the analog output of the receiver
 - The display shows the note played and both LEDs HI or LO showing how close it is to the correct pitch. If you reached the final pitch the LED OK lights up
- **TUNER OFF**
 - Press the switch TUNER ON/OFF (10), to end the tuner operation. If the tuner is not in use (*no input signal*) for ~90 sec. the display will be switched off. This is shown by a flashing dot of the display
- **PAIRING:** For first time use or if you want to operate a transmitter with a different receiver you need to "pair" these as follows:
 - **1st on the Receiver:** If the system is not paired the PAIRING LED (14) flashes slow. Now press the switch PAIRING (13) for around ½ sec. The blue PAIRING LED (14) starts to flash faster. After successful pairing the blue LED will be on steady.
 - **Note:** You have ~15 sec. time to pair a transmitter to the receiver! Otherwise you must start the pairing process again.
 - **2nd on the Transmitter:** After starting the pairing process on the receiver press and hold (~1 sec.) the switch TUNER ON/OFF (10). This starts the pairing function of the transmitter.
 - The LED (11) flashes alternating red and green. After a successful pairing the blue element of the LED (11) will be on steady.

△ Blue flashing of the LED (11) or PAIRING LED (2) on the receiver indicate that there is no communication between transmitter and receiver. This may possible if the system is not paired, or the distance between transmitter and receiver is too long or the occurrence of any other trouble.

- **PHASE:** Depending on the environment some feedback - which means awkward sound on one frequency - may occur. This has a physical background and depends on the position between your instrument and speaker. A good method to lower the risk of feedback is to turn the phase by 180° to change the physical conditions. Very often it helps, but sometimes it will support the feedback or just change the frequency of the feedback. In this case switch the phase back and try to change your position.
 - To change the phase press the switch WIRELESS ON/OFF just shortly
 - Depending on the state of phase the LED (11) lights up GREEN or RED for a moment.
- **VOLUME CONTROL**
 - Turn the volume control to get your desired volume. We suggest not selecting too low levels for normal operation – otherwise the "signal to noise ratio" is not as good

PAN CONTROL

- Controls the amount of effect between mono and stereo.
- See **Fig. 5** for details
- For stereo operation you must use a 2 channel amplifier (*E.g. Mixer*)

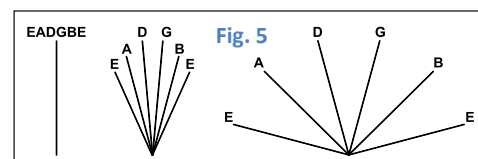

BT-T CONTROL: To control the tone for the lower treble strings [G-B-E]. It works like a bass/treble rocker:

- Middle position: Flat sound
- **Fig. 6:** If you turn the pot away from the center positions either bass or treble increases.
- If bass is increasing (**A**) the treble will stay flat!
- Same if you increase treble (**B**): Bass will stay flat

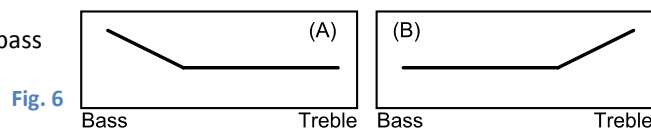

BT-B CONTROL

- Same function as BT-T control but controls the sound for the upper strings [E-A-D]

OVERLOAD: The transmitters ADC detects overloaded input signals.

- If the input is too high (*E.g. heavy strumming*) the LED (11) lights up with all colors, when linked = white for a moment.
- In this case increase the distance between strings and pickup.

Startup the Panorama Receiver

Controls of the Panorama Receiver

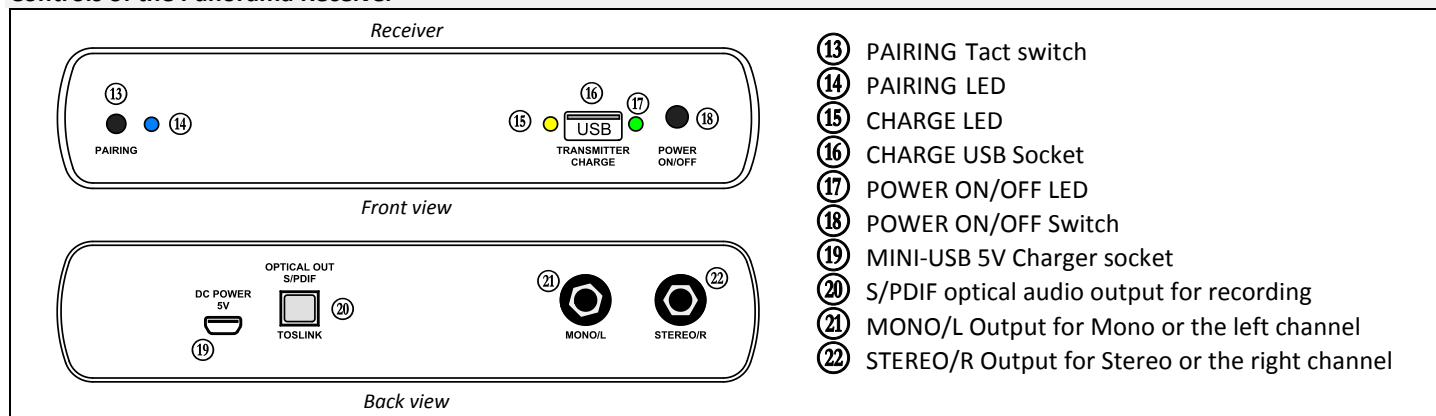

- ⑬ PAIRING Tact switch
- ⑭ PAIRING LED
- ⑮ CHARGE LED
- ⑯ CHARGE USB Socket
- ⑰ POWER ON/OFF LED
- ⑱ POWER ON/OFF Switch
- ⑲ MINI-USB 5V Charger socket
- ⑳ S/PDIF optical audio output for recording
- ㉑ MONO/L Output for Mono or the left channel
- ㉒ STEREO/R Output for Stereo or the right channel

Connections

- **POWER:** Connect the USB cable (type A to MICRO B) between USB Charger and the rear USB socket ⑲ of the receiver.
 - The yellow LED ⑮ lights up and you can use the front USB socket ⑯ to charge the transmitter.

- **POWER ON/OFF**

- Push the switch POWER ON/OFF ⑱ to switch the receiver on or OFF.
- The green LED ⑰ lights up. If equipped, the red SHADOW logo on the front will light up too.

- **AUDIO OUTPUT:** You have 3 options:

- **MONO OPERATION:** Connect a "Mono Cable" (TS*¹ plug) between jack ㉑ and an amplifier (E.g. mixer or guitar amplifier)
- **STEREO OPERATION with "2 Mono Cables":** Connect two cables (TS plug) between jack ㉑ and ㉒ and two channels of your amplifier. (E.g. mixer)
- **STEREO OPERATION with a "Y-Cable":** Connect the stereo plug (TSR*² plug) to the jack ㉒, the opposite ends (TS plug) to two channels of a stereo amplifier. Set the channel 1 and 2 pan pots on the amplifier to the left and right position!

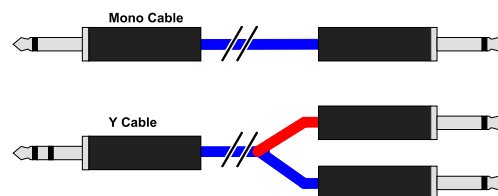

- △ *¹TS: Tip, Sleeve of a ¼" mono plug
- △ *²TSR: Tip, Sleeve, Ring of a ¼" stereo plug

- **DIGITAL OUTPUT (S/PDIF):** For digital reproduction connect an optical TOSLINK cable (not provided) between the TOSLINK output ⑳ and your device. First remove the dust cap before you insert the TOSLINK cable. Note that this is the real digital output signal without Volume, Pan Mute, and BT-T, BT-B control settings. This is best for reworking the digital signal with your audio software (not provided) on the computer. Note: The S/PDIF is affected with a slight pre-emphasis from the transmitter side!
- **USING other transmitter with the receiver:** You always can setup another Shadow transmitter of the same family with the receiver. Just follow the instruction for **PAIRING**. **Note:** A receiver can play the actual paired transmitter only!

△ **Note:** When you switch the receiver off and on again, it needs a little time until the settings of the transmitter are transferred to the receiver. During this time you may hear the previous setting shortly before it changes to the new settings. This is normal and not a malfunction!

Special Functions

This system has an intelligent Frequency-Selecting-Procedure. Depending on the environment it searches for the best RF channel. This works on 3 different frequency bands: 2.4GHz, 5.2GHz and 5.8GHz. In some countries 5.2 and/or 5.8GHz are not allowed. For this you can deselect these frequency bands. This system has FCC and CE certificates to use all 3 bands in the US and Europe. For Japan we offer a special version to meet Japanese requirements. It is possible that RF regulations in your country may vary after printing this manual. In case you need updated information please visit our website for the latest manuals.

If you need to select or deselect frequency bands, first you have to set the transmitter to the **SERVICE MODE**:

- **ENTER SERVICE MODE**

- The transmitter must be switched off first, then press the switch Tuner ⑩ to start the **TUNER ONLY MODE**.
- Press and hold both Wireless ON/OFF ⑤ AND Tuner ⑩ at the same time (for ~1 sec.) to enter the **SERVICE MODE**.
- The LED ⑪ indicates this by alternate flashing between green and red.

- **SHOW VERSION + BATTERY STATE:** In the **SERVICE MODE** press the switch Wireless ON/OFF ⑤:

- Display (Blink code) of the hardware version, followed by the battery charge state: (lights up for ~4 sec.)
 - Blue = Very good condition
 - Cyan = Good
 - Green = Normal
 - Yellow = Weak
 - Red = Very weak

LED Colors	
Cyan	= Blue and Green
Yellow	= Green and Red
Purple	= Red and Blue
White	= Red, Green and Blue

After showing the transmitter is back in the **SERVICE MODE**.

• SELECT THE FREQUENCY BAND*

- First select the **SERVICE MODE** than press switch Tuner (10). The LED (11) flashes fast and shows the actual frequency selection.
- With the switch Wireless ON/OFF (5) you can walk (7 steps) through the selection as follows:
- After you set the desired selection, press the switch Tuner (10) again.

The selection is stored and the transmitter is back to the **SERVICE MODE**.

USA / EUROPE	
1. White = 2.4 + 5.2 + 5.8 * ³	5. Cyan = 5.2 + 5.8
2. Red = 2.4	6. Green = 5.2
3. Yellow = 2.4 + 5.2	7. Blue = 5.8
4. Purple = 2.4 + 5.8	

*³ Default (Allowed in USA and Europe)

JAPAN Version only	
1. White = 2.4 + 5.2 * ⁴	5. Cyan = 5.2
2. Red = 2.4	6. Green = 5.2
3. Yellow = 2.4 + 5.2	7. Blue = 2.4
4. Purple = 2.4	

*⁴ Default (Allowed in Japan)

• QUIT SERVICE MODE

- Press and hold the switch Wireless ON/OFF (5) to switch off the unit.

• INVOKE TEST MODE: Note: For test and service only!

- First select the **SERVICE MODE**.
- Again press both switches Wireless ON/OFF (5) AND Tuner (10) at the same time (for ~1 sec.) to invoke the **TEST MODE**. Now the receiver changes its sound settings automatically controlled by the transmitter.
- After execution the transmitter switches back to the **SERVICE MODE**

***OBEY THE LAWS AND RULES
IN THE COUNTRY YOU WANT
TO USE THIS RF SYSTEM!**

△ **RESET:** In case of trouble you can reset the system by removing the battery for some seconds.
This will not change the Frequency Band selection!

TECHNICAL DATA

- Power Supply / Charger 100-240VAC 50/60Hz 5V/1.0A switching adapter *⁵ with 3 power adaptors for US, UK, and Europe. Output socket: USB type A. You can use any other standard 5V USB source to charge. (E.g. computer)
- USB Cable(s) USB type A to type Micro B
- 3.7V LI-ION Battery Commercial Lithium Ion battery: Like NP120 with a capacity of ~1700mA/h. Running up to 6 hours
- RF Frequency 2.4, 5.2 and 5.8GHz. Indoor use only! 5.2/5.8GHz can be switched off to fulfill the rules and regulation of your country where you operate this system.
- Range approx. 100ft. (30m) – depends on the environment. WLAN devices may disturb proper operation
- Transmission 3 channel digital transmission. (2x dig. audio, 1x data)
- Audio 2 digital channels with 48kHz sampling frequency *⁶
- Output Impedance 6kΩ
- ADC Max. 24-Bit Conversion, 114dB Dynamic Range, -105dB THD+N, Overflow Detection
- DAC Max. 24-Bit Conversion, 113dB Dynamic Range, -94dB THD+N, SNR 113dB
- Opt. Output S/PDIF, Toslink, Stereo, 16bit, 48kHz, I2S
- Latency time ca. 6.9ms. This is an additional distance between your instrument and speaker of 7½ft (2.3m) only!

*⁵ During normal operation or charge operation you may notice a high tone out of the Charger. This is normal and not a malfunction!

*⁶ During operation with magnetic pickup, slight digital noise caused by energized magnetic field may be noticed!

Additional Information about this product

Update information may be found on our website: <http://shadow-electronics.com>

There you can find manuals in different languages too. E.g. in German / Spanish!

Errors and omissions excepted - Subject to change without prior notice!

